

Super Systems Inc. Model DPC2500 –continuous dew point analyzer

Product manual

INTRODUCTION –

THANKS! – for choosing Super Systems Inc. as your supplier and the DPC2500 as your continuous Dew Point Analyzer.

UNPACKING

Carefully unpack the Model DPC2500 Dew Point Analyzer. If there are any signs of shipping damage, notify *SSI* and the shipper. If a camera is available it is recommended that pictures be taken to show the damage to the relevant parties.

NOTE:

Keep this instruction book in a secure place and refer to it when there is a question about the analyzer.



Table Of contents

INTRODUCTION –	1
UNPACKING	1
NOTE:.....	1
OPERATION -	3
HOW IT WORKS –	3
WHAT IT MEASURES –	3
FACTORY CALIBRATION -	5
FIELD CALIBRATION -	5
FIELD CALIBRATION - CONTINUED	6
SPARE PARTS –	7

Super Systems Inc.

Model DPC2500 –continuous dew point analyzer

Product manual

OPERATION -

HOW IT WORKS -

Heat Treat Furnace Sampling: A gas sample can be extracted from a process by the built-in pump. The sample tube with which the sample is taken from the furnace should be Quartz, Inconel or RA330 stainless steel. It should extend into the furnace, past the HOT face of the refractory. The built-in pump will pull a sample of approximately 1.5 - 2.0 SCFH.

Endothermic Generator Sampling: For applications under pressure, the pump may be switched off and the flow controlled by the small valve on the flow meter. The sample should be taken from the endothermic gas manifold after the gas has been cooled. **Allow the sample port “to blow out any soot” before connecting the sample tube.** A sample volume of 1.5 - 2.0 SFCH through the flow meter is required.

The dew point sensor is a “dielectric ceramic” that varies its electrical capacitance with changes in relative humidity.

The dual RH/temperature sensor is mounted in a short probe which in turn is installed in a “T” fitting that allows the sample gas to flow pass the sensor.

The microprocessor accurately calculates the dew point from these RH and Temperature inputs. The resultant dew point is displayed on the LED digital meter.

WHAT IT MEASURES -

This analyzer is designed to measure dew point in gases which are **non corrosive**. **Gases that cause damage or failure to the sensor are trace amounts of SO₃, Chlorine, HCL, etc.** The range of measurement of this analyzer is -50°F to +80°F.

One of the added features of the DPC2500 is the ability to monitor the sensor’s “operating” temperature. It has a built-in thermister temperature sensor to determine its “dry bulb” temperature. Monitoring the sensor’s temperature while using the unit (maintaining a temperature of less than 140° F.) will insure a long and productive sensor life.

MISCELLANEOUS -

4-20mA outputs are provided so that the Dew Point (in the range of -50°F to +80°F.) is available for data collection.

Super Systems Inc.

Model DPC2500 –continuous dew point analyzer

Product manual

STARTUP –

The DPC2500 Dewpoint Analyzer was calibrated before it was shipped from Super Systems Inc. You should begin operation by applying power, only after the unit has been allowed to stabilize to a temperature close to ambient near the equipment being measured. This is particularly important for units that have been sitting overnight in a delivery van in sub-zero weather.

After power is applied allow the DPC2500 to warm up for approximately 3 minutes.

When connecting the sample hose to either the furnace or the generator, **make sure that the bowl filter (P/N 37048 or equivalent) is clean and functional** (for generator operation you should turn the pump toggle switch “OFF”). Maintain at least a 1.5 - 2.0 SCFH atmosphere flow through the analyzer.

Remember that the sample line for the furnace should extend beyond the HOT face of the refractory. Using a “GOOD” sample port assures that a good sample is available.

NOTE:

A “GOOD” sample port is defined as a continuous tube that extends past the hot face of the refractory and is free of SOOT or other contaminants. **If the sample line is contaminated with SOOT, the DP2000 may read HIGH on furnace applications.**

Periodically check the external filter for contamination. If dirty, replace filter. The cleaner the filter, the more consistent and accurate the dew point reading.

A good, stable dew point reading should be available two (2) minutes after the DP2000 Dew Point Analyzer begins sampling the atmosphere.

Super Systems Inc.

Model DPC2500 –continuous dew point analyzer

Product manual

FACTORY CALIBRATION -

It is suggested that this device should be calibrated on a routine basis, such as once every 6 months or as prescribed by the user's quality system requirements.

FIELD CALIBRATION -

To perform a field calibration, obtain the optional **CALIBRATION KIT** (P/N 31030).

This kit consists of two bottles of saturated salt solution in which each bottle generates a precise relative humidity.

One bottle is 11.3% R.H. and the other 75.3% R.H. These two calibration points are already programmed into the microprocessor board.

Step No. 1 - To begin the calibration, simply open the door by unlatching the clamps.

Locate the microprocessor board shown below on the bottom right-hand corner of the panel. On the board there are three tiny pushbuttons as shown below.

Super Systems Inc.

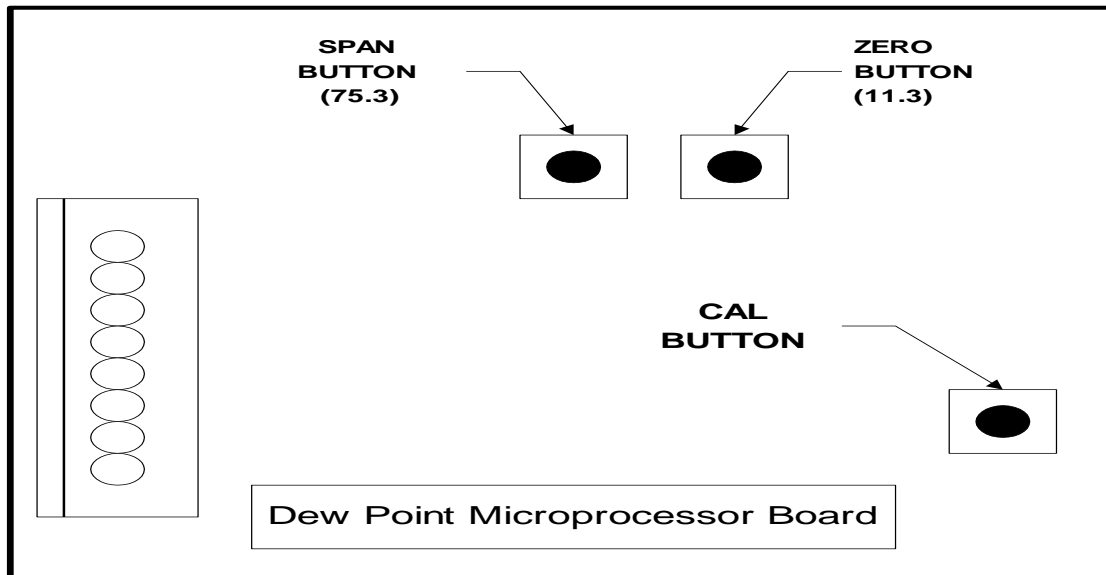

Model DPC2500 –continuous dew point analyzer

Product manual

FIELD CALIBRATION - Continued

Step No. 2 - Next, remove the R.H./TEMP sensor probe from its flow through chamber by loosening the black plastic gland nut, sliding it out through its seal. Note that the probe has a white mark at the wire entry point, which must be aligned with the corresponding white mark in plastic gland. This ensures correct probe position in sample gas flow chamber.

Step No. 3 - Slip the black sensor seal that is supplied with the calibration kit, over the probe. Then snug up the large nut to tighten the grip around the probe.

Step No. 4 - Screw the black seal into the 75.3% R.H. bottle.

Step No. 5 - Turn off the analyzer and wait about eight (8) hours. By then the sensor will have fully settled on the correct amount of R.H. in the bottle.

Step No. 6 - Turn the unit "ON".

Step No. 7 - Press the "**CAL BUTTON**" and the "**SPAN BUTTON**" simultaneously. Release both buttons. See drawing – Page 5.

NOTE:

Do not be concerned if the front panel display does not read 75.3. The display is reading the equivalent computed dew point.

Step No. 8 - Next, unscrew the black seal from the 75.3% R.H. bottle and install it into the 11.3% R.H. bottle.

Step No. 9 – Turn off the UNIT – wait a minimum of twelve **(12) hours**.

Step No. 10 – Turn the UNIT "ON" and Press the "**CAL BUTTON**" and the "**ZERO BUTTON**" simultaneously. Release both buttons. See drawing – Page 5

The DPC2500 is now calibrated.

Step No. 11 - Remove the probe from the black seal and replace it in the sample gas flow chamber, watching for white mark alignment. Tighten the black screw to seal the sensor. Close the analyzer cover.

NOTE: Be sure that when returning the sensor to the "flow through chamber" that the mirror is facing the incoming gas stream by correct white mark alignment.

Step No. 12 - Replace the caps in the bottles and store them in a cool, dry place.

Super Systems Inc.
 Model DPC2500 –continuous dew point analyzer

Product manual

TERMINAL BLOCK WIRING

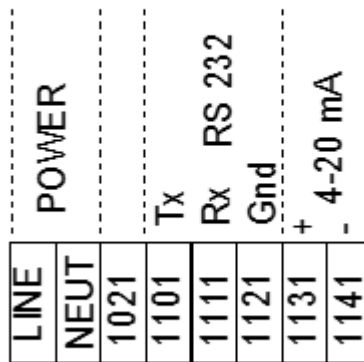

SPARE PARTS –

Description	Part No.
Factory Calibration _____	13045
Sample Pump _____	31401
Filter _____	37048
Replacement filter element _____	31027
Flow meter _____	36027
Microprocessor Display Board _____	31501
Dew Point Sensor _____	31038
Calibration Kit _____	31030

Revision History

Rev.	Description	Date
-	Initial Release	11-01-2000
A	Added Revision History Page	07-09-2001
B	SSi Address Update, General Update	04-13-2005
C	Corrected terminal block wiring chart	3/18/2020
D	Adjusted calibration interval text	3/25/2021

Super Systems Inc.

USA Office

Corporate Headquarters:

7205 Edington Drive

Shipping Address:

7245 Edington Drive

Cincinnati, OH 45249

Phone: (513) 772-0060

<http://www.supersystems.com>

Super Systems Europe

Unit E, Tyburn Trading Estate,

Ashold Farm Road, Birmingham

B24 9QG

UNITED KINGDOM

Phone: +44 (0) 121 306 5180

<http://www.supersystemseurope.com>

Super Systems México

Sistemas Superiores Integrales S de RL de CV

Acceso IV No. 31 Int. H Parque Industrial

Benito Juarez

C.P. 76120 Queretaro, Qro.

Phone: +52 442 210 2459

<http://www.supersystems.com.mx>

Super Systems China

No. 369 XianXia Road

Room 703

Shanghai, CHINA

200336

Phone: +86 21 5206 5701/2

<http://www.supersystems.cn>

Super Systems India Pvt. Ltd.

A-26 Mezzanine Floor, FIEE Complex,

Okhla Indl. Area, Phase - 2

New Delhi, India 110 020

Phone: +91 11 41050097

<http://www.supersystemsindia.com>